

Instruction For Integration

MB-60 Motor Board

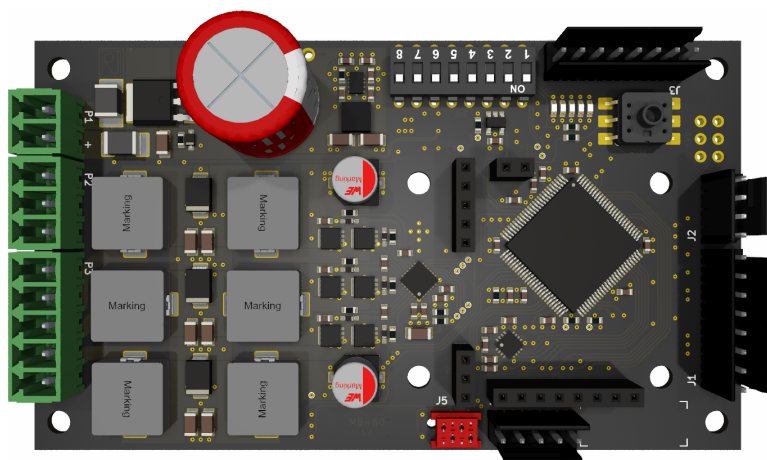

Contents

1	Introduction	3
2	MB-60 Motor Board	3
2.1	Description	3
2.2	Characteristics	3
2.3	Power Supply	4
2.4	Connection	4
2.5	Protections	6
2.6	Impedances	6
2.7	Wiring	6
2.8	Variants	6
3	Accessories	7
3.1	AB-60 Adaptator	7
3.2	RT-60 Router	8
3.3	CP-13 Panel	10
4	Implantation	11
4.1	Fastening, Connecting & Cooling	11
4.2	Optional pressure sensor	11
4.3	Configuration	11
5	Electromagnetic Compatibility	13
5.1	Precautions regarding electromagnetic compatibility	13
5.2	Guidance and manufacturer's declaration	13
6	Precautions	16
6.1	Intended use & Safety	16
6.2	Maintenance & Repair	16
6.3	Environmental conditions	16
6.4	Recycling & Disposal	16

Revisions

2026-05-18	Bo	1.2	Amended release
2025-10-10	Bo	1.1	Initial release
2025-02-22	Bo	1.0	Initial version

1 Introduction

This instruction for integration covers the installation of the **Dassym MB-60** motor board, which is common to several **Dassym** medical devices. Users shall first read their instruction for use.

⚠ WARNING This equipment is intended for integration into a dental unit and cannot be used stand alone. The unit manufacturer is responsible for proper integration and compliance of its unit as a whole. No claim can be inferred if this product is not installed in accordance with **Dassym** prescriptions.

2 MB-60 Motor Board

2.1 Description

The **MB-60** (or **MB-60-NP** without pressure captor) motor driver board receives commands, either digital or analog, from the dental unit and sends controlled electrical energy to the motor.

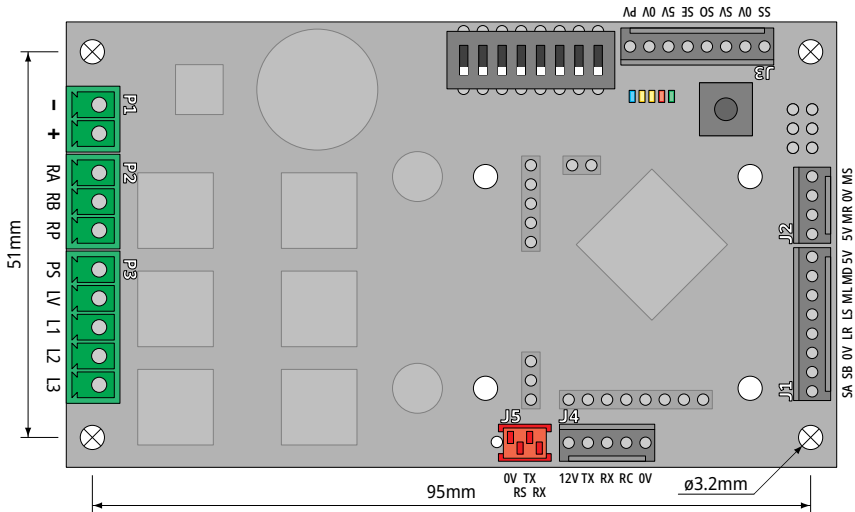

2.2 Characteristics

251.60.000 (MB-60) / 251.60.100 (-NP)	Minimum	Typical	Maximum	Unit
Dimensions		102 × 59 × 29		mm
Mass		60		g
Supply Voltage	24	32 – 36	48	V _{DC}
Maximum Consumption	180	240	360	W

Rated voltage is 32 – 36 V_{DC}. Optimal function is not guaranteed outside of this range. Limits must in no case be exceeded.

2.3 Power Supply

Power supply should be of good quality, with enough bulk capacitance and low internal resistance. In order to ensure proper system function, power supply must be tested in the worst case scenario to verify that voltage ripple stays within the 1% of the nominal voltage requirement.

Rated power supply voltage is 32 – 36 V_{DC}. Optimal performance is achieved with at least 240 VA power supply. In no case should the power supply deliver less than 120 VA.

2.4 Connection

Optional and external components shall be wired according to the following prescriptions.

2.4.1 Power Connectors

P1 Supply

Pin name	Wire	Color	Description	Type	Voltage	Current	
1	-	≥ 0.5 mm ² (20 AWG)	Black	Negative Supply	P _{IN}	0 V _{DC}	8 A _{MAX}
2	+	≥ 0.5 mm ² (20 AWG)	Red	Positive Supply	P _{IN}	24 ... 48 V _{DC}	8 A _{MAX}

P_{IN}: Power input. Protected against polarity inversion. Voltage ripple shall not exceed 1% of the nominal voltage.

Cable length: < 1 m (3 ft). WE WR-TBL plug, eg. 691361300002 (screws) or 691304300002 (screwless).

P2 Router

Pin name	Wire	Color	Description	Type	Voltage	Current	
1	RA	≥ 0.34 mm ² (22 AWG)	Black	Relay A Solenoid	O _{DR}	0 ... 32 V _{DC}	120 mA
2	RB	≥ 0.34 mm ² (22 AWG)	Gray	Relay B Solenoid	O _{DR}	0 ... 32 V _{DC}	120 mA
3	RP	≥ 0.34 mm ² (22 AWG)	Red	Relay Power	P _{OUT}	16 ... 32 V _{DC}	120 mA

P_{OUT}: Power output, O_{DR}: Open drain. Relay / valve solenoid 24V_{DC} nominal voltage, outputs current controlled.

To be mounted directly over the main board, without wires. If wire are used, electromagnetic compliance must be verified.

P3 Motor

Pin name	Wire	Color	Description	Type	Voltage	Current	
1	PS	≥ 0.25 mm ² (24 AWG)	Brown	Phantom Supply	P _{OUT}	-3 ... 48 V _{DC}	360 mA
2	LV	≥ 0.25 mm ² (24 AWG)	Blue	Light Voltage	P _{OUT}	0 ... 45 V _{DC}	360 mA
3	L1	≥ 0.34 mm ² (22 AWG)	Red	Motor Phase 1	P _{OUT}	0 ... 45 V _{DC}	8 A _{PEAK}
4	L2	≥ 0.34 mm ² (22 AWG)	Black	Motor Phase 2	P _{OUT}	0 ... 45 V _{DC}	8 A _{PEAK}
5	L3	≥ 0.34 mm ² (22 AWG)	Green	Motor Phase 3	P _{OUT}	0 ... 45 V _{DC}	8 A _{PEAK}

P_{OUT}: Power output. PS and LV voltages depend on motor type. For each phase, mean current is 2/3 peak current.

Cable length: < 1.8 m (6 ft) with WE 7427113 ferrite. WE WR-TBL plug, 691361300005 (screws) or 691304300005 (screwless).

2.4.2 Signal Connectors

J1 Control

Pin name	Wire	Color	Description	Type	Voltage	Current
1 SA	≥ 0.25 mm ² (24 AWG)	Blue	A Select	D _{INP}	0 ... 48 V _{DC}	< 1 mA
2 SB	≥ 0.25 mm ² (24 AWG)	Green	B Select	D _{INP}	0 ... 48 V _{DC}	< 1 mA
3 0V	≥ 0.25 mm ² (24 AWG)	Black	Ground Reference	G _{REF}	0 V _{DC}	
4 LR	≥ 0.25 mm ² (24 AWG)	Yellow	Light Reference	A _{INP}	0 ... 5 V _{DC}	< 1 mA
5 LS	≥ 0.25 mm ² (24 AWG)	Pink	Light Switch	A _{INP}	0 ... 5 V _{DC}	< 1 mA
6 ML	≥ 0.25 mm ² (24 AWG)	Violet	Motor Limit	A _{INP}	0 ... 5 V _{DC}	< 1 mA
7 MD	≥ 0.25 mm ² (24 AWG)	Black	Motor Direction	D _{INP}	0 ... 48 V _{DC}	< 1 mA
8 5V	≥ 0.25 mm ² (24 AWG)	Brown	5 V Supply	P _{OUT}	5 V _{DC}	100 mA

G_{REF}: Ground reference, P_{OUT}: Power output, A_{INP}: Analog input 50 kΩ pull up, D_{INP}: Digital input 50 kΩ pull up.

Cable length: < 1 m (3 ft). WE WR-WTB plug, 661008113322 (crimps) or 661008151922 (crimpless).

J2 Pedal

Pin name	Wire	Color	Description	Type	Voltage	Current
1 5V	≥ 0.25 mm ² (24 AWG)	Yellow	5 V Supply	P _{OUT}	5 V _{DC}	100 mA
2 MR	≥ 0.25 mm ² (24 AWG)	Gray	Motor Reference	A _{IN}	0 ... 5 V _{DC}	< 1 mA
3 0V	≥ 0.25 mm ² (24 AWG)	Black	Ground Reference	G _{REF}	0 V _{DC}	
4 MS	≥ 0.25 mm ² (24 AWG)	White	Motor Switch	D _{INP}	0 ... 48 V _{DC}	< 1 mA

G_{REF}: Ground reference, P_{OUT}: Power output, A_{IN}: Analog input 50 kΩ pull down, D_{INP}: Digital input 50 kΩ pull up.

Cable length: < 3 m (10 ft). WE WR-WTB plug, 661004113322 (crimps) or 661004151922 (crimpless).

J3 Option

Pin name	Wire	Color	Description	Type	Voltage	Current
1 SS	≥ 0.25 mm ² (24 AWG)	Green	S Select	D _{INP}	0 ... 48 V _{DC}	< 1 mA
2 0V	≥ 0.25 mm ² (24 AWG)	Black	Ground Reference	G _{REF}	0 V _{DC}	
3 SV	≥ 0.25 mm ² (24 AWG)	Violet	Scaler Voltage	A _{OUT}	0 ... 5 V _{DC}	5 mA
4 SO	≥ 0.25 mm ² (24 AWG)	Pink	Scaler Option	D _{OUT}	0 ... 5 V _{DC}	5 mA
5 SE	≥ 0.25 mm ² (24 AWG)	Yellow	Scaler Enable	D _{OUT}	0 ... 5 V _{DC}	5 mA
6 5V	≥ 0.25 mm ² (24 AWG)	Brown	5 V Supply	P _{OUT}	5 V _{DC}	250 mA
7 0V	≥ 0.25 mm ² (24 AWG)	Black	Ground Reference	G _{REF}	0 V _{DC}	
8 PV	≥ 0.25 mm ² (24 AWG)	Orange	Power Supply	P _{OUT}	24 ... 48 V _{DC}	500 mA

G_{REF}: Ground reference, P_{OUT}: Power output, A_{OUT}: Analog output, D_{OUT}: Digital output, D_{INP}: Digital input 50 kΩ pull up.

Cable length: < 1 m (3 ft). WE WR-WTB plug, 661008113322 (crimps) or 661008151922 (crimpless).

J4 Panel

Pin name	Wire	Color	Description	Type	Voltage	Current	
1	12V	≥ 0.25 mm ² (24 AWG)	Red	12 V Supply	P _{OUT}	12 V _{DC}	250 mA
2	TX	≥ 0.25 mm ² (24 AWG)	White	RS-232 Transmit	D _{OUT}	-5 ... 5 V _{DC}	25 mA
3	RX	≥ 0.25 mm ² (24 AWG)	Pink	RS-232 Receive	D _{IN}	-5 ... 5 V _{DC}	< 1 mA
4	RC	≥ 0.25 mm ² (24 AWG)	Gray	Relay C Solenoid	O _{DR}	0 ... 32 V _{DC}	120 mA
5	0V	≥ 0.25 mm ² (24 AWG)	Black	Ground Reference	G _{REF}	0 V _{DC}	

G_{REF}: Ground reference, P_{OUT}: Power output, D_{OUT}: Digital output, O_{DR}: Open drain, D_{IN}: Digital input with 5 kΩ load.

Cable length: < 0.5 m (1.5 ft). WE WR-WTB plug, 661005113322 (crimps) or 661005151922 (crimpless).

J5 Master

Pin name	Wire	Color	Description	Type	Voltage	Current	
1	0V	≥ 0.25 mm ² (24 AWG)	Gray	Ground Reference	G _{REF}	0 V _{DC}	
2	RS	≥ 0.25 mm ² (24 AWG)	Gray	Master Reset	O _{DP}	0 ... 5 V _{DC}	5 mA
3	TX	≥ 0.25 mm ² (24 AWG)	Gray	RS-232 Transmit	D _{OUT}	-5 ... 5 V _{DC}	25 mA
4	RX	≥ 0.25 mm ² (24 AWG)	Gray	RS-232 Receive	D _{IN}	-5 ... 5 V _{DC}	< 1 mA

G_{REF}: Ground reference, D_{OUT}: Digital output, O_{DP}: Open drain 50 kΩ pull up, D_{IN}: Digital input with 5 kΩ load.

Cable length: < 0.5 m (1.5 ft). WE WR-MM plug 690157000472 (flat cable).

2.5 Protections

Power inputs P_{IN} are protected against over voltage. Power outputs P_{OUT} are protected against over current. Digital D_{OUT} and analog A_{OUT} outputs are protected against over current. Digital D_{IN} and analog A_{IN} inputs are protected against over voltage. No additional protections are required.

2.6 Impedances

Power P_{OUT} and Open Drain O_{DR} Outputs are about 1 Ω impedance, hence able to drive significant loads. Digital D_{OUT} and analog A_{OUT} outputs are about 200 Ω impedance, hence able to drive at least 5 mA with 1 V swing. Digital D_{IN} and analog A_{IN} inputs are at least 5 kΩ impedance, hence driven by less than 1 mA under 5 V. For heavy loads, wire impedance should be taken in account.

2.7 Wiring

To ensure proper function, wire gauge shall not be less than recommended: 0.5 mm² (AWG 20) for power lines, 0.34 mm² (AWG 22) for motor phases, 0.25 mm² (AWG 24) for other connections.

2.8 Variants

Contrary to the full **MB-60** (ref. **251.60.000**), the **MB-60-NP** (ref. **251.60.100**) doesn't include the pressure captor and is intended for those who do not need a pneumatic speed reference.

3 Accessories

3.1 AB-60 Adaptator

3.1.1 Description

The AB-60 Adaptator is intended for integration of the MB-60 in a unit which provides low voltage alternating current — typically $24 V_{AC}$ — from an isolation transformer.

The AB-60 Adaptator provides full wave rectification, adequate bulk capacitance and power line electromagnetic interference filtering for conformal function of the system.

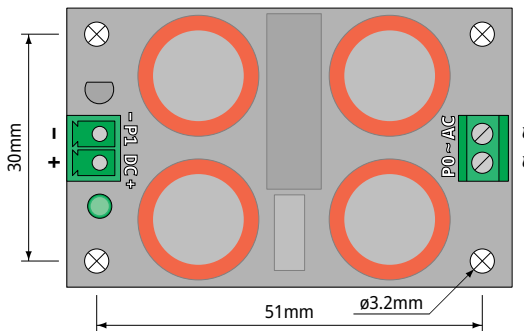

3.1.2 Characteristics

259.60.001	Minimum	Typical	Maximum	Unit
Dimensions		59 × 37 × 29		mm
Mass		50		g
AC Input Frequency	48	50 – 60	62	Hz
AC Input Voltage	18	24 – 28	36	V_{AC}

Rated voltage is 24 – 28 V_{AC} . Optimal function is not guaranteed outside of this range. Limits must in no case be exceeded.

3.1.3 Connectors

P0 AC Supply

Pin name	Wire	Color	Description	Type	Voltage	Current	
1	~	≥ 0.5 mm ² (20 AWG)	Brown	Alternating Supply	P_{IN}	18 ... 36 V_{AC}	8 A_{MAX}
2	~	≥ 0.5 mm ² (20 AWG)	Brown	Alternating Supply	P_{IN}	18 ... 36 V_{AC}	8 A_{MAX}

P_{IN} : Power input. Protected against transients and surges. Mains transformer must be adequately fused.

Cable length not specified, but impedance loss must be taken in account. Direct wire screwing.

P1 DC Output

Pin name	Wire	Color	Description	Type	Voltage	Current	
1	-	≥ 0.5 mm ² (20 AWG)	Black	Negative Output	P _{OUT}	0 V _{DC}	8 A _{MAX}
2	+	≥ 0.5 mm ² (20 AWG)	Red	Positive Output	P _{OUT}	24 ... 48 V _{DC}	8 A _{MAX}

P_{OUT}: Power output. Ripple voltage in volts is roughly equal to load current in amperes.

Cable length: < 1 m (3 ft). WE WR-TBL plug, 691361300002 (screws) or 691304300002 (screwless).

3.2 RT-60 Router

3.2.1 Description

The RT-60 Router enables the MB-60 to provide two motor connections — any combination of the Dassym MO-xx motors, with each motor to be selected alternatively.

Motor selection is provided by the MB-60 according to the scheme configured by the DIP switches. Please refer to the MB-60 and RT-60 instructions for further information.

The RT-60 Router also provides a solenoid driver expansion which enables actuation of low power valves following the motor selection scheme.

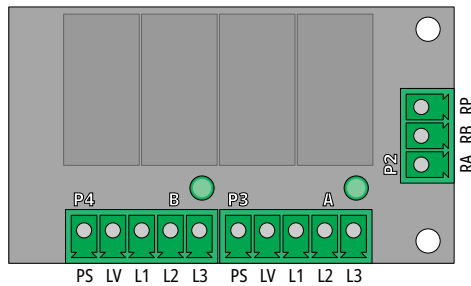

3.2.2 Characteristics

255.60.001	Minimum	Typical	Maximum	Unit
Dimensions		59 × 34 × 33		mm
Mass		40		g
Relays Voltage	16	24 – 28	32	V _{DC}
Relays Current	40	60	80	mA
Relays Consumption	0.6	1.4	2.5	W

Total current with additional solenoids connected must not exceed 120 mA or about 2.5W total power.

3.2.3 Connectors

P2 Relays

Pin name	Wire	Color	Description	Type	Voltage	Current
1 RA	≥ 0.34 mm ² (22 AWG)	Black	Relay A Solenoid	O _{DR}	0 ... 32 V _{DC}	60 mA
2 RB	≥ 0.34 mm ² (22 AWG)	Gray	Relay B Solenoid	O _{DR}	0 ... 32 V _{DC}	60 mA
3 RP	≥ 0.34 mm ² (22 AWG)	Red	Relay Power	P _{OUT}	16 ... 32 V _{DC}	60 mA

P_{OUT}: Power output, O_{DR}: Open drain. Relay / valve solenoid 24V_{DC} nominal voltage, outputs current controlled.

Cable length: < 1 m (3 ft). WE WR-TBL plug, eg. 691361300003 (screws) or 691304300003 (screwless).

P3 Motor A

Pin name	Wire	Color	Description	Type	Voltage	Current
1 PS	≥ 0.25 mm ² (24 AWG)	Brown	Phantom Supply	P _{OUT}	-3 ... 48 V _{DC}	360 mA
2 LV	≥ 0.25 mm ² (24 AWG)	Blue	Light Voltage	P _{OUT}	0 ... 45 V _{DC}	360 mA
3 L1	≥ 0.34 mm ² (22 AWG)	Red	Motor Phase 1	P _{OUT}	0 ... 45 V _{DC}	8 A _{PEAK}
4 L2	≥ 0.34 mm ² (22 AWG)	Black	Motor Phase 2	P _{OUT}	0 ... 45 V _{DC}	8 A _{PEAK}
5 L3	≥ 0.34 mm ² (22 AWG)	Green	Motor Phase 3	P _{OUT}	0 ... 45 V _{DC}	8 A _{PEAK}

P_{OUT}: Power output. PS and LV voltages depend on motor type. For each phase, mean current is ⅔ peak current.

Cable length: < 1.8 m (6 ft) with WE 7427113 ferrite. WE WR-TBL plug, 691361300005 (screws) or 691304300005 (screwless).

P4 Motor B

Pin name	Wire	Color	Description	Type	Voltage	Current
1 PS	≥ 0.25 mm ² (24 AWG)	Brown	Phantom Supply	P _{OUT}	-3 ... 48 V _{DC}	360 mA
2 LV	≥ 0.25 mm ² (24 AWG)	Blue	Light Voltage	P _{OUT}	0 ... 45 V _{DC}	360 mA
3 L1	≥ 0.34 mm ² (22 AWG)	Red	Motor Phase 1	P _{OUT}	0 ... 45 V _{DC}	8 A _{PEAK}
4 L2	≥ 0.34 mm ² (22 AWG)	Black	Motor Phase 2	P _{OUT}	0 ... 45 V _{DC}	8 A _{PEAK}
5 L3	≥ 0.34 mm ² (22 AWG)	Green	Motor Phase 3	P _{OUT}	0 ... 45 V _{DC}	8 A _{PEAK}

P_{OUT}: Power output. PS and LV voltages depend on motor type. For each phase, mean current is ⅔ peak current.

Cable length: < 1.8 m (6 ft) with WE 7427113 ferrite. WE WR-TBL plug, 691361300005 (screws) or 691304300005 (screwless).

3.2.4 Mounting

RT-60 is to be installed on top of the MB-60. Two nylon spacers^a are provided for firm fastening. Total system height (MB-60 + RT-60) is then 40 mm.

^a WE-SNSN 701515000.

3.3 CP-13 Panel

3.3.1 Description

The CP-13 Panel — along with its keypad^a — is intended to provide a standalone interface to the user. Please refer to the CP-13 instruction for further information about usage.

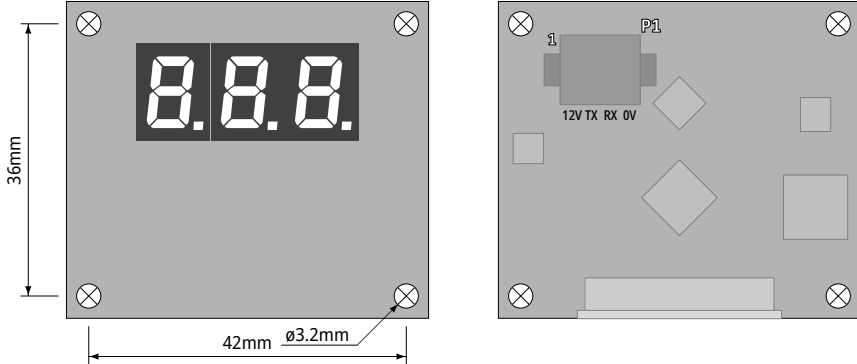

3.3.2 Characteristics

250.13.001	Minimum	Typical	Maximum	Unit
Dimensions		48 × 42 × 12		mm
Mass		12		g
Power Supply Voltage	8	10 – 12	14	V _{DC}
Power Consumption		0.3	0.9	W

Rated voltage is 10 – 12 V_{DC}. Power consumption depends on the overall display brightness and the buzzer function.

3.3.3 Connectors

P1 Board

Pin name	Wire	Color	Description	Type	Voltage	Current
1 12V	≥ 0.25 mm ² (24 AWG)	Red	12 V Supply	P _{IN}	8 ... 14 V _{DC}	<75 mA
2 TX	≥ 0.25 mm ² (24 AWG)	Pink	RS-232 Transmit	D _{OUT}	-5 ... 5 V _{DC}	25 mA
3 RX	≥ 0.25 mm ² (24 AWG)	White	RS-232 Receive	D _{IN}	-5 ... 5 V _{DC}	< 1 mA
4 0V	≥ 0.25 mm ² (24 AWG)	Black	Ground Reference	G _{REF}	0 V _{DC}	

G_{REF}: Ground reference, P_{IN}: Power input, D_{OUT}: Digital output, D_{IN}: Digital input with 5 kΩ load, withstands ± 25 V_{DC}. Maximum cable length: 0.5 m (1.5 ft). Flexicon spring connector for direct wire fastening (strip 6 mm of isolation).

^a The KP-10 Keypad for example, ref. 051.000.042. There is also a CP-12 Panel (2-digit version) available, ref. 250.12.001.

P2 Keypad

This connector is intended to receive the flat cable of a Dassym keypad. Pin affectation may vary with the keypad type and is not available to the user.

3.3.4 Mounting

CP-13 is intended to be mounted in a plastic case with at least 2.5 mm (0.1 in) creepage distance between circuit board and front face along with at least 5 mm (0.2 in) isolation from metal parts.

4 Implantation

This product must be installed by qualified personal only. During integration, only use a medical power supply that conforms to IEC 60601-1 standard, respecting the required withstand voltage, creepage distances and distances in air.

The example block diagram on the following page is for reference only. Installer should coordinate with Dassym in order to validate his specific implantation scheme, if need be.

4.1 Fastening, Connecting & Cooling

All Dassym boards shall be tightly fastened to their support with M3 (1/8 in) spacer studs. Isolation from any metal part, fixture, chassis or enclosure shall be at least 5 mm (0.2 in).

The electronic boards are to be isolated from protective earth. Common ground reference is done through the 0V connecting wires. All connections shall be wired according to specifications (cable length, wire section and plug type) provided in this document. Motor hoses and connections shall conform to Dassym standard^a.

The electronic boards don't require special cooling measures unless unusually high duty is to be expected. The customer should consult with Dassym in case of doubt. Dassym MO-x3 motors are not intended to run without forced air cooling. Depending on specific application, Dassym MO-x4 motors may run without forced air cooling.

4.2 Optional pressure sensor

The MB-60 may be delivered with an optional pressure sensor which acts as speed reference. In case the board is configured to use the pressure sensor, the electric speed reference is inactive.

4.3 Configuration

System configuration is performed through the MB-60 DIP switches. Factory default configuration is usually optimal for most situations. Please refer to the MB-60 configuration^b for details.

^a The HO-35 Hose for example, ref. 121.35.001.

^b MB-60 Instruction for Configuration.

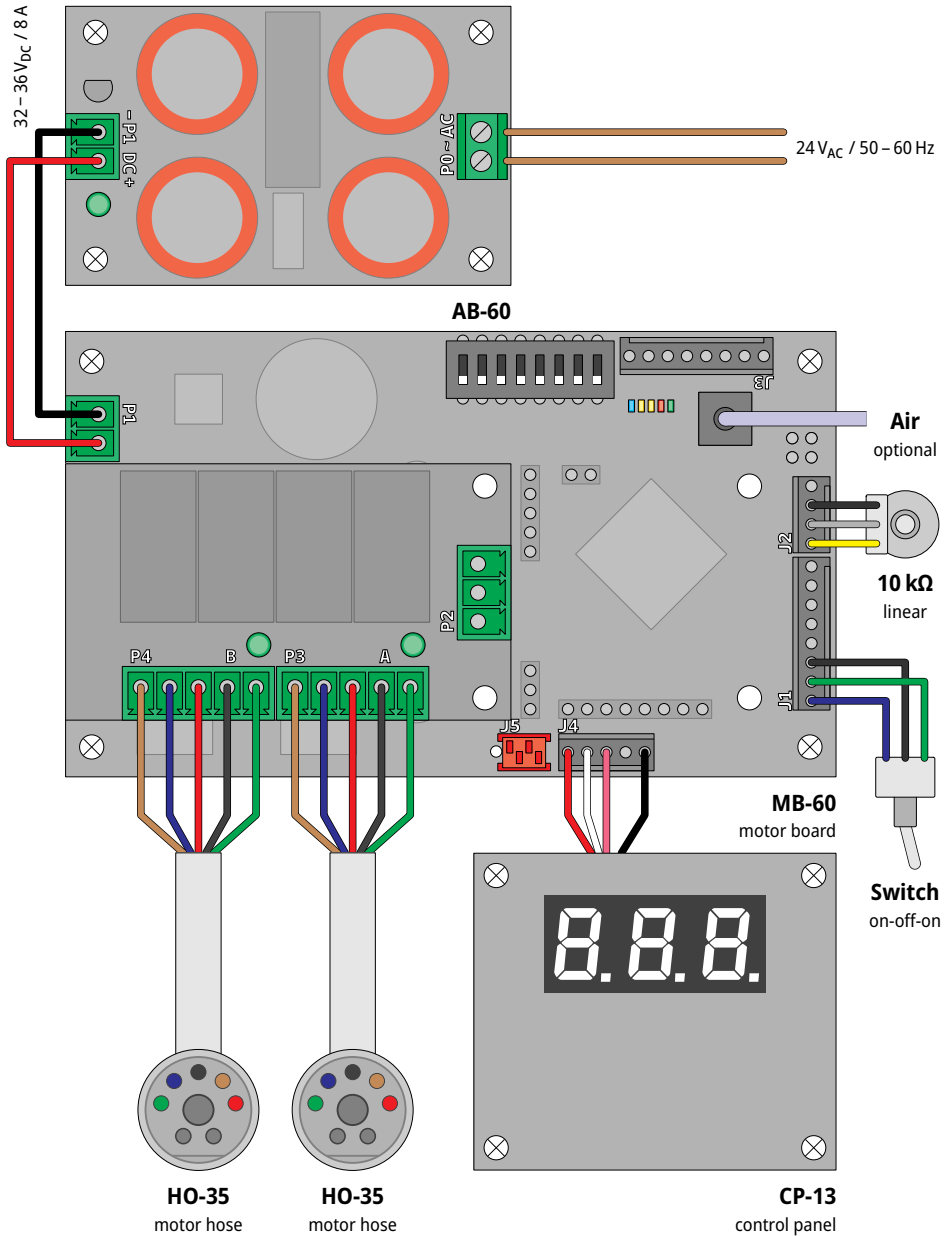

5 Electromagnetic Compatibility

5.1 Precautions regarding electromagnetic compatibility

Medical electrical equipment needs special precautions regarding EMC and shall be installed and put into service according to EMC information provided in this document.

This product is intended to be used in a home or professional healthcare environment.

Special precautions must be taken when using strong emission sources such as High Frequency surgical equipment and similar so that the HF cables are not routed in the vicinity of the device.

- ⚠ CAUTION** Use of this equipment adjacent to or stacked with other equipment should be avoided because it could result in improper operation. If such use is necessary, this and the other equipments should be observed to verify that they are operating normally.
- ⚠ CAUTION** Use of accessories and cables other than those specified by Dassym may result in increased emissions or decreased immunity of this equipment and might lead to improper operation. Compliant cables and accessories are specified in sections 2.4 – 3.1 – 3.2 – 3.3 of this instruction for integration.
- ⚠ CAUTION** Portable RF communications equipment (including peripherals such as antenna cables and external antennas) should be used no closer than 30 cm (12 inches) to any part of this equipment, including cables specified by the manufacturer. Degradation of the performance of this equipment could result otherwise.

5.2 Guidance and manufacturer's declaration

The product is intended for use in the electromagnetic environment specified below. The customer shall assure that it is used in such an environment.

5.2.1 Electromagnetic emissions

<i>Emission test</i>	<i>Compliance level^a</i>	<i>Guidance</i>
RF emissions CISPR 11	Group 1	The system only uses RF energy for its internal function. Its RF emissions are therefore very low and are not likely to cause any interference in nearby electronic equipment.
	Class B	The system is suitable for use in all establishments, including domestic establishments and those directly connected to the public low voltage network that supplies buildings used for domestic purposes.
RF emissions CISPR 14-1		The main functions of this medical equipment are performed by motors and switching or regulating devices.

^a As of IEC 60601-1-2:2014 + AMD1:2020 Edition 4.1.

5.2.2 Electromagnetic immunity

Immunity test	Compliance level ^a	Guidance
Electrostatic discharges IEC 61000-4-2	±8 kV contact ±2 ±4 ±8 ±15 kV air	Floors shall be wood, concrete or ceramic. If floors are covered with synthetic material, relative humidity shall be at least 30 %.
Radiated RF IEC 61000-4-3	10 V/m: 80 MHz – 2.7 GHz 80 % AM @ 1 kHz	If the measured field strength in the location where the system is used exceeds the applicable RF compliance level, the system should be observed to verify normal operation.
Proximity field from RF wireless communication equipment IEC 61000-4-3	27 V/m: 380 – 390 MHz 50 % PM @ 18 Hz 28 V/m: 430 – 470 MHz FM ±5 kHz, 1 kHz sine 9 V/m: 704 – 787 MHz 50 % PM @ 217 Hz 28 V/m: 800 – 960 MHz 50 % PM @ 18 Hz 28 V/m: 1700 – 1990 MHz 50 % PM @ 217 Hz 28 V/m: 2400 – 2570 MHz 50 % PM @ 217 Hz 9 V/m: 5100 – 5800 MHz 50 % PM @ 217 Hz	If abnormal performance is observed, additional measures may be necessary, such as reorienting or relocating the system. Minimum separation distance shall be calculated according to the following equation: $E = \frac{6}{d} \sqrt{P}$ where: <i>E</i> is the immunity test level in V/m, <i>d</i> is the minimum separation in m, <i>P</i> is the maximum power in W. Portable RF communications equipment (including peripherals such as antenna cables and external antennas) should be used no closer than 30 cm (1 ft) to any part of the system, including cables specified by the manufacturer. Interference may occur in the vicinity of equipment marked with the following symbol: 
Conducted RF IEC 61000-4-6	6 V _{rms} : 150 KHz – 80 MHz outside ISM bands ^b & radio amateur band ^c 10 V _{rms} : 150 KHz – 80 MHz in ISM bands ^b & radio amateur band ^c	
Proximity fields IEC 61000-4-39	8 A/m: 30 kHz CW 65 A/m: 134.2 kHz 50 % PM @ 2.1 kHz 7.5 A/m: 13.56 MHz 50 % PM @ 50 kHz	
Electrical fast transients IEC 61000-4-4	±2 kV power supply line	Mains power quality should be that of a typical commercial or hospital environment.
Surges IEC 61000-4-5	±1 kV power line to line ±2 kV power line to earth	
Magnetic fields IEC 61000-4-8	30 A/m @ 50 – 60 Hz	Mains frequency magnetic fields should be at levels characteristic of a typical location in a commercial or hospital environment.
Voltage dips and interruptions IEC 61000-4-11	0 % UT for 0.5 cycle @ 0°, ±45°, ±90°, ±135°, 180° 0 % UT for 1 cycle and 70 % UT for 25 / 30 cycles @ 0° 0 % UT for 250 / 300 cycles @ 0°	If the user of the device requires continued operation during mains power interruptions, it is recommended that the device be powered from an uninterruptible power supply or a battery.

^a As of IEC 60601-1-2:2014 + AMD1:2020 Edition 4.1.

^b The industrial, scientific and medical bands between 150 kHz and 80 MHz are 6.765 – 6.795 MHz, 13.553 – 13.567 MHz, 26.957 – 27.283 MHz and 40.66 – 40.7 MHz.

^c The amateur radio bands between 150 kHz and 80 MHz are 1.8 MHz – 2 MHz, 3.5 – 4 MHz, 5.3 – 5.4 MHz, 7 – 7.3 MHz, 10.1 – 10.15 MHz, 14 – 14.2 MHz, 18.07 – 18.17 MHz, 21 – 21.4 MHz, 24.89 – 24.99 MHz, 28 – 29.7 MHz and 50 – 54 MHz.

5.2.3 Recommended separation distances

This medical equipment is intended for use in an electromagnetic environment in which radiated RF disturbances are controlled. The customer or user of the medical equipment can help prevent electromagnetic interference by maintaining a minimum distance between portable and mobile RF communications equipment (transmitters) and the medical equipment as recommended below, according to the maximum output power of the communications equipment.

Rated maximum output power of transmitter [W]	Separation distance according to transmitter frequency [m]		
	0.15 – 80 MHz ^a $d = 1.2\sqrt{P}$	0.15 – 80 MHz ^b $d = 2.0\sqrt{P}$	80 – 5800 MHz ^c $d = 0.60\sqrt{P}$
0.01	0.12	0.20	0.06
0.1	0.38	0.63	0.19
1	1.2	2.0	0.60
10	3.8	6.3	1.9
100	12	20	6.0

^a Outside ISM (industrial, scientific and medical) and radio amateur bands, see § 5.2.2 notes ^b & ^c for details.

^b In ISM (industrial, scientific and medical) and radio amateur bands, see § 5.2.2 notes ^b & ^c for details.

^c For RF wireless transmitters, see § 5.2.2 — Proximity field from RF wireless communication equipment.

For transmitters rated at a maximum output power not listed above, the recommended separation distance can be estimated using the equation applicable to the frequency of the transmitter according to the transmitter manufacturer, where d is measured in meters [m] and P in watts [W].

5.2.4 Essential performance

This dental equipment does not have essential performance. Anyway, it has demonstrated no loss nor significant degradation of its function due to EM disturbances.

6 Precautions

6.1 Intended use & Safety

This product is intended to be used in a home or professional healthcare environment. Refer to the Dassym instructions^a for further details about intended use and safety information.

- ⚠ DANGER** Do not use this product in areas subject to explosion hazards.
- ⚠ WARNING** This equipment must only be used by professionals in compliance with legal provisions in force regarding occupational safety, health and accident prevention measures. In accordance with these provisions, the user is responsible for ensuring he or she only uses devices which are in a perfect working order.

6.2 Maintenance & Repair

The Dassym MB-60 motor driver board doesn't need regular maintenance.

- ⚠ WARNING** This equipment shall be repaired only by Dassym approved qualified personal.

6.3 Environmental conditions

	Working			Storage & Transport		
	Min	Max	Unit	Min	Max	Unit
Temperature range	+10	+35	°C	-40	+70	°C
Relative humidity range (keep away from rain)	10	80	%	5	85	%
Air pressure range	70	106	kPa	50	106	kPa

6.4 Recycling & Disposal

Electrical and electronic equipment may contain dangerous substances which constitute health and environmental hazards. The user must return the device to its dealer or establish direct contact with an approved body for treatment and recovery of this type of equipment (European Directive 2012/19/EU).



^a www.dassym.com/ifu



Dassym SA
Route de Séprais 19a
2856 Boécourt
SWITZERLAND

SRN: CH-MF-000048199
www.dassym.com
info@dassym.com

Active patents
CH709334, EP2858589



Veranex Germany GmbH
Landsberger Straße 302
80687 München
GERMANY

SRN: DE-AR-000005578
www.veranex.com
info@veranex.com

